

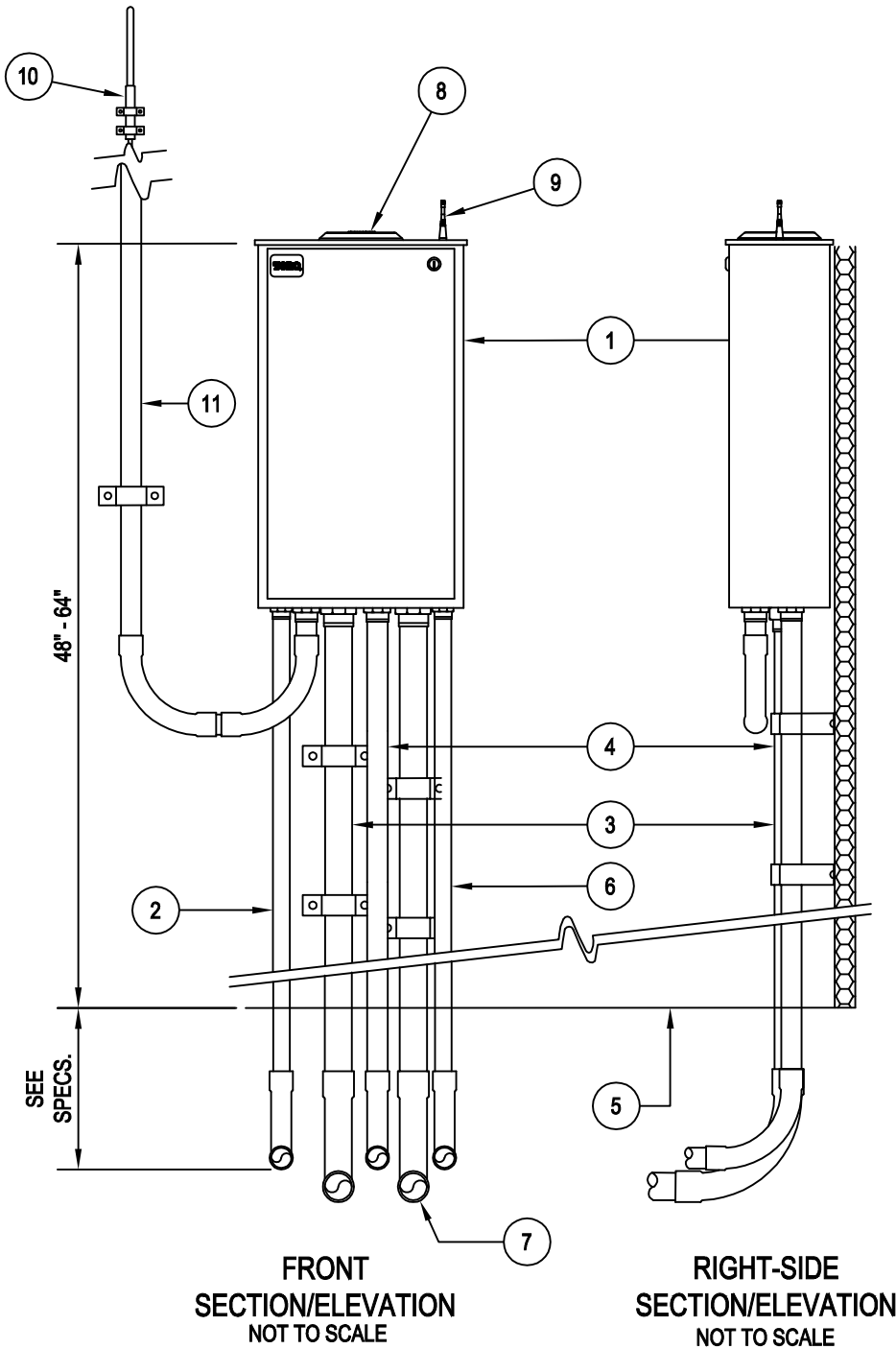

TORO-IRRIGATION DIVISION
 5825 JASMINE STREET
 RIVERSIDE, CA 92504
 TOLL FREE: 1-877-345-8676
 FAX: (951) 359-1870
 www.toro.com



- 1 TORO SENTINEL IRRIGATION CONTROLLER MODEL NO. SBDWS5U (DC) OR SBAWS5U (AC)
- SEE PLANS FOR NUMBER OF STATIONS
- ANCHOR SECURLY TO WALL
- 2 3/4" CONDUIT FOR ELECTRICAL POWER CONDUCTORS PER LOCAL AND NATIONAL CODES
- 3 2" CONDUIT FOR TWO-WIRE PATH
- SECURE TO WALL WITH APPROPRIATE PIPE CLAMPS
- 4 3/4" CONDUIT FOR EARTH GROUND
- 5 FINISHED SURFACE
- 6 1/2" CONDUIT FOR SENSOR WIRES
- 7 OPTIONAL 2" CONDUIT FOR SECOND TWO-WIRE PATH
- 8 STANDARD 400MHZ ANTENNA FOR PRIMARY COMMUNICATION
- 9 900MHZ ANTENNA FOR OPTIONAL WIRELESS SOIL SENSOR ADD-ON MODEL NO. TPS-RX
- 10 OPTIONAL OMNI DIRECTIONAL ANTENNA PER SITE SURVEY RECOMMENDATIONS MODEL NO. SB-ANT-MAST
- 11 OPTIONAL 1-1/2" CONDUIT FOR ANTENNA WIRE MINIMUM RADIUS ON SWEEP SHALL BE 1-1/2"

NOTES:

- 1. INSTALLATION TO BE COMPLETED IN ACCORDANCE WITH MANUFACTURERS SPECIFICATIONS.
- 2. DO NOT SCALE DRAWINGS.
- 3. CONTRACTORS NOTE: FOR PRODUCT AND COMPANY INFORMATION VISIT www.CADdetails.com/info REFERENCE NUMBER 065-121.

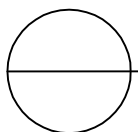

SENTINEL TWO-WIRE WALL-MOUNT CONTROLLER

WS5 STAINLESS STEEL CABINET