

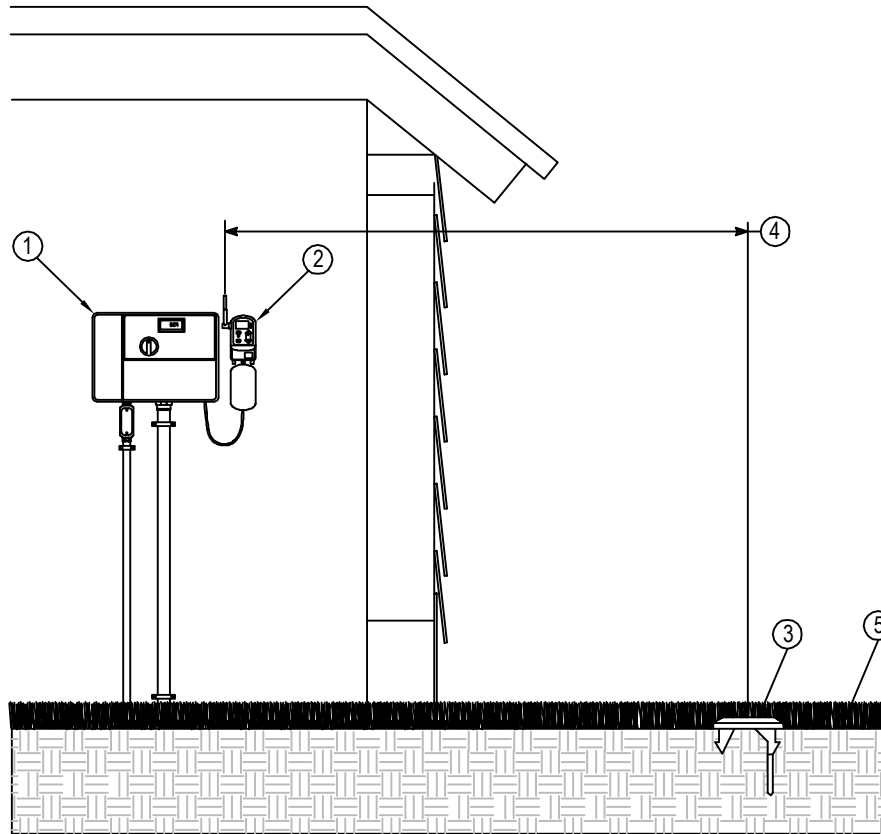

TORO-IRRIGATION DIVISION
 5825 JASMINE STREET
 RIVERSIDE, CA 92504
 TOLL FREE: 1-877-345-8676
 FAX: (951) 359-1870
 crc@toro.com
 www.toro.com



LEGEND:

- ① IRRIGATION CONTROLLER
- ② SENSOR RECEIVER SECURED TO WALL WITH APPROPRIATE FASTENERS AND WIRED TO THE IRRIGATION CONTROLLER'S 24V TERMINAL AND SENSOR PORT (OR COMMON WIRE).
- ③ SENSOR PROBE INSTALLED IN A REPRESENTATIVE AREA OF THE GROUNDS.
- ④ DISTANCE BETWEEN SENSOR PROBE AND RECEIVER NOT TO EXCEED 500 FEET LINE OF SIGHT.
- ⑤ FINISHED GRADE.

NOTES:

1. INSTALLATION TO BE COMPLETED IN ACCORDANCE WITH MANUFACTURER'S SPECIFICATIONS.
2. DO NOT SCALE DRAWING.
3. THIS DRAWING IS INTENDED FOR USE BY ARCHITECTS, ENGINEERS, CONTRACTORS, CONSULTANTS AND DESIGN PROFESSIONALS FOR PLANNING PURPOSES ONLY. THIS DRAWING MAY NOT BE USED FOR CONSTRUCTION.
4. ALL INFORMATION CONTAINED HEREIN WAS CURRENT AT THE TIME OF DEVELOPMENT BUT MUST BE REVIEWED AND APPROVED BY THE PRODUCT MANUFACTURER TO BE CONSIDERED ACCURATE.
5. CONTRACTOR'S NOTE: FOR PRODUCT AND COMPANY INFORMATION VISIT www.CADdetails.com/info AND ENTER REFERENCE NUMBER 065-467A.

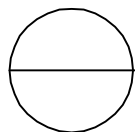

PRECISION SOIL SENSOR APPLICATION VIEW

WIRELESS SOIL MOISTURE SENSOR