

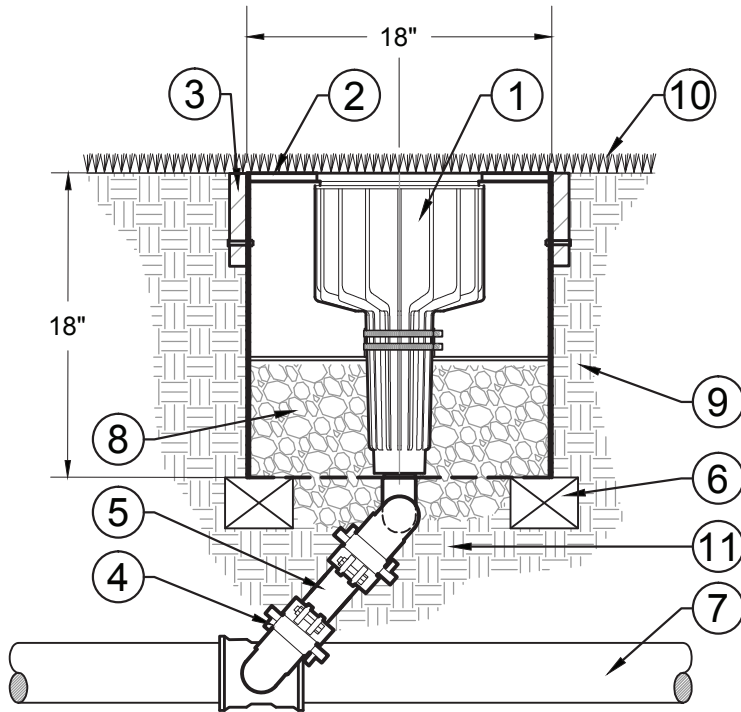

TORO-IRRIGATION DIVISION
 5825 JASMINE STREET
 RIVERSIDE, CA 92504
 TOLL FREE: 1-800-664-4740
 PHONE: (951) 785-3152
 FAX: (951) 359-1870
 www.toro.com

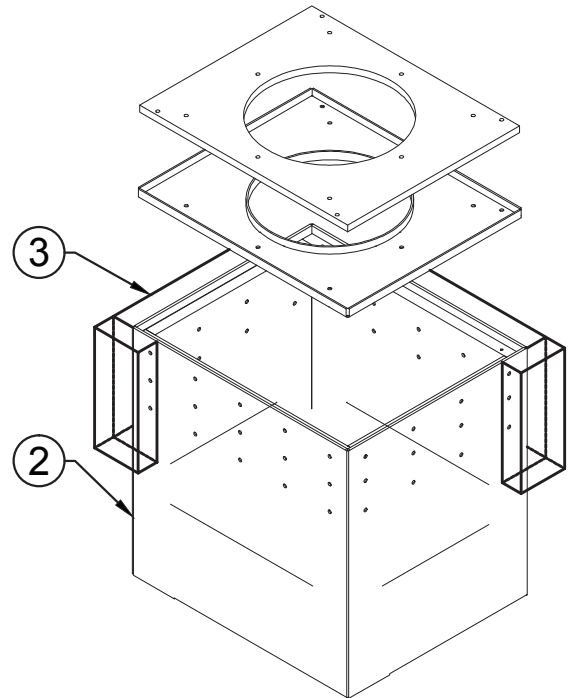

SECTION ELEVATION:



CORNER ELEVATION:

LEGEND:

- ① TORO TS120 SERIES SPRINKLER
- ② TORO STAINLESS STEEL ENCLOSURE (MODEL NUMBER TSSBKC-18-120). 18" x 18" x 18" SST ENCLOSURE W/ RECESSED SST LID AND 1/2" THICK HDPE INSERT, AND INTEGRATED UNIVERSAL CLAMP TO MAINTAIN VERTICALITY OF SPRINKLER.
- ③ SIDE SUPPORTS – ADJUST FOR VARYING PILE HEIGHTS. SECURE TO ALL FOUR SIDES OF EACH ENCLOSURE. SUPPLIED BY OTHERS.
- ④ DUCTILE IRON SWING JOINT ASSEMBLY – 1-1/2" X NPT FOR SPRINKLER INLET (MODEL NUMBER TS120-SJ-150-NDI)
- ⑤ PVC PIPING – 1-1-1/2" SCHEDULE 40 PVC – LENGTH AS REQUIRED – PROVIDED BY OTHERS.
- ⑥ COMMON RED OR CONCRETE BRICK SUPPORT UNDER EACH CORNER OF BOX.
- ⑦ IRRIGATION WATER LINE PIPING AND TEE FITTING SUPPLIED BY OTHERS.
- ⑧ 3/4" WASHED GRAVEL BACKFILL - SET TO 6-INCHES BELOW BOX.
- ⑨ COMPACTED SUB-GRADE.
- ⑩ FINISH GRADE.
- ⑪ COMPACTED SUB-BASE MATERIAL.

NOTES: 1. IN GROUND ENCLOSURE TO WITHSTAND HEAVY TRAFFIC WITHOUT DEFLECTION.
 2. BOX BASE INCLUDES 2.5" RETURN FOR STABILITY WITHIN SOILS.
 3. ALL HARDWARE SHALL BE STAINLESS STEEL.

TORO® TS120 with DUCTILE IRON SWING JOINT